

# 양자 신경망 기반 NOMA 시스템 파라미터 구성

이만희<sup>1</sup>, 이해영<sup>1</sup>, 박진수<sup>2</sup>, 박재한<sup>2</sup>, 신수용<sup>\*</sup>

국립금오공과대학교<sup>1</sup>, 국립금오공과대학교 IT융복합공학과<sup>2</sup>

{fordmore, lhy413, jp, qkrwogks7094, wdragon\*}@kumoh.ac.kr

## System Parameter Configuration for QNN-NOMA

Man Hee Lee, Hye Yeong Lee, Jin Soo Park, Jae Han Park, Soo Young Shin

Kumoh National Institute of Technology

### Abstract

In this paper, the non orthogonal multiple access (NOMA) system parameter is considered for quantum neural network (QNN). The NOMA system model consists of a base station (BS) and two user equipment (UEs). Simply, a imperfect parameter of SIC is given as constant value. To find optimal solution in neural network (NN), establishing significant parameter is necessary. Therefore, this progress of work will introduce the extension of QNN-NOMA. The performance analysis of proposed model is simulated in terms of spectral efficiency (SE).

### I. Introduction

Non orthogonal multiple access (NOMA) has suggested to serve multiple users sharing in same frequency resources. In NOMA, each user operates in the same frequency and time where they are distinguished by their power levels. NOMA uses superposition coding at the transmitter and apply the successive interference cancellation (SIC) at the receiver[1]. NOMA has been proposed as a candidate radio access technology for 5G cellular systems due to its superior spectral efficiency (SE)[2].

The quantum neural network (QNN) has studied to solve resource allocation to reduce the complexity while maintaining satisfied performance[3]. As a similar approach with classical neural network (CNN), a QNN utilizes quantum bits (Qubits) instead of the classical bits in a CNN.

### II. System model

In this section, we suggest a NOMA system model consists of a base station (BS) and two user equipments (UEs). The BS has two antennas to communicate with near and far UEs (UE1 and UE2). The UEs equip a single antenna with BS. It is assumed that a single pairing is given for NOMA system.

The received symbol for UEs is expressed as

$$y = \sum_{i=1}^2 h_i \{ \sqrt{\rho\phi_1} s_1 + \sqrt{\rho\phi_2} s_2 \} + \omega_i \quad (1)$$

where  $h_i$  is the Rayleigh fading channel for  $i$ -th user with zero mean and  $\lambda_i$  variance.  $s_1$  and  $s_2$  denote the transmit symbol for UE1 and UE2, respectively.  $\rho$  is transmit power.  $\phi_1$  and  $\phi_2$  denote the power allocation coefficient for UE1 and UE2, respectively. In addition,  $\omega_i$  is the additive white Gaussian noise for  $i$ -th user with zero mean and unit variance.

Following the proposed system model, the SE of UE1 and UE2 can be expressed as

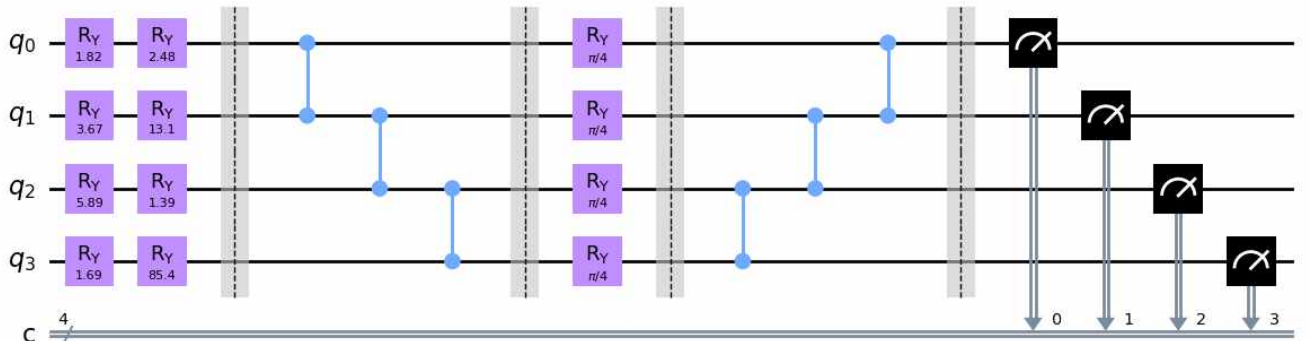

Figure 1 quantum circuit of QNN

$$R_1 = \log_2 \left( 1 + \frac{\rho\phi_1|h_1|^2}{N_t} \right)$$

$$R_2 = \log_2 \left( 1 + \frac{\rho\phi_2|h_2|^2/N_t}{\zeta\rho\phi_1|h_2|^2/N_t + 1} \right) \quad (2)$$

where  $\zeta$  is an imperfect parameter of SIC.  $N_t$  is the number of transmit antennas.

The quantum circuit of QNN is shown in Figure 1. The CNOT gate is used to make quantum entanglement[4].

### III. Simulation results

In this section, we describe the simulation results in terms of SE. The simulation parameters are given that the number of access point (AP) and receive antennas are 4 and 2, respectively. The number of users are given as 4 to make two user pairing groups for NOMA. The transmit SNR starts from zero to 10[dB]. The size of training data is given as 200. The learning rate is given as 0.1. The number of Qubits are used 4 identifying with the number of transmit antennas. The backend of QNN is used as QSAM simulator which has 30 Qubits[5].

In Figure 2, the SE comparison is shown with respect to the transmit SNR.

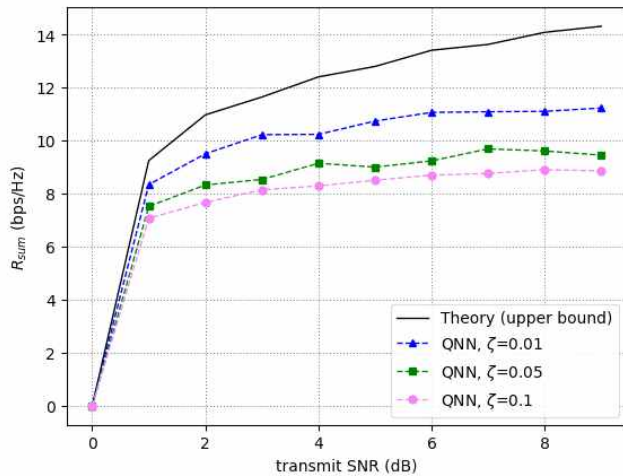

Figure 2 SE comparison

### IV. Conclusion

In this paper, we describe the parameter selection for establishing QNN-NOMA system model. The simulation results show the loss calculation and SE comparison for a progress of the QNN-NOMA system model. To find optimal solution, selecting significant parameter is necessary in NN. This practical approach will introduce the extension of current work for future research.

### ACKNOWLEDGMENT

This research was supported by Basic Science Research Program through the National Research Foundation of Korea(NRF) funded by the Ministry of Education(No. 2022R1I1A1A01066178)

This research was supported by the MSIT(Ministry of Science and ICT), Korea, under the ICAN(ICT Challenge and Advanced Network of HRD) program(IITP-2022-RS-2022-00156394) supervised by the IITP(Institute of Information & Communications Technology Planning & Evaluation)

### REFERENCES

- [1] Xia, Bin, et al. "Outage performance analysis for the advanced SIC receiver in wireless NOMA systems." *IEEE Transactions on Vehicular Technology* 67.7 (2018): 6711-6715.
- [2] Benjebbovu, Anass, et al. "System-level performance of downlink NOMA for future LTE enhancements." *2013 IEEE globecom workshops (GC Wkshps)*. IEEE, 2013.
- [3] Narottama, Bhaskara, and Soo Young Shin. "Quantum neural networks for resource allocation in wireless communications." *IEEE Transactions on Wireless Communications* 21.2 (2021): 1103-1116.
- [4] Qi, Jun, Chao-Han Yang, and Pin-Yu Chen. "Qtn-vqc: An end-to-end learning framework for quantum neural networks." *Physica Scripta* 99.1 (2023): 015111.
- [5] Bishop, Lev S. "Qasm 2.0: A quantum circuit intermediate representation." *APS March Meeting Abstracts*. Vol. 2017. 2017.